



www.mazzer.com



MAJOR



Accessori Opzionali / Optionals / Options / Optionals / Opciones / Opções

- Dosatura maggiorata (8-10,5 g) / Oversize dose (8-10,5 g - 0,28-0,36 oz) / Dose majorée (8-10,5 g) / Erhöhte Dosierung (8-10,5 g) / Dosis aumentada (8-10,5 g) / Dose maior (8-10,5 g)

- Pressino a molla con forchetta lunga / Spring coffee pressing device with long fork / Presse-café à ressort avec fourchette longue / Kleine Feder-presser mit langer Stützgabe / Prensador con resorte y horquilla larga / Prensador con mola e forquilha comprida

- Easy Tamper per dosatore / Easy Tamper for doser / Easy Tamper pour doseur / Easy Tamper für Dosierer / Easy Tamper para dosificador / Easy Tamper para doseador

COLOURS

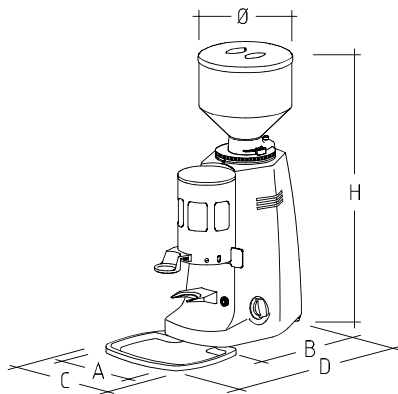

	mm	inches
A	212	8 ¼
B	292	11 ½
C	240	9 ½
D	455	18
H	635	25
Ø	212	8 ¼



MACINADOSATORE MAJOR

REGOLAZIONE DI MACINATURA MICROMETRICA CONTINUA

Disponibile nelle versioni:
- con interruttore manuale
- con interruttore a tempo
- automatico con avviamento ogni 12 dosi ed arresto al riempimento del dosatore

CARATTERISTICHE TECNICHE:

Potenza	650 Watt
Macine	Ø 83 mm
(monofase rif. 151A - trifase rif. 151B)	
Giri macine	1400 (50 Hz) g/min
	1600 (60 Hz) g/min
Capacità contenitore caffè in grani	1,8 Kg
Peso netto	20 Kg



MOULIN DOSEUR MAJOR

RÉGULATION DE MOUTURE MICROMÉTRIQUE CONTINUE

Disponibile dans les versions suivantes:
- avec interrupteur manuel
- avec interrupteur à temps
- automatique avec démarrage toutes les 12 doses et arrêt à remplissage du doseur de café moulu

CARACTÉRISTIQUES TECHNIQUES:

Puissance	650 Watt
Meules	Ø 83 mm
(monophasé réf. 151A - triphasé réf. 151B)	
Tours meules	1400 (50 Hz) tr/min
	1600 (60 Hz) tr/min
Contenance de la trémie	1,8 Kg
Poids net	20 Kg



GRINDER-DOSER MAJOR

STEPLESS MICROMETRICAL GRINDING ADJUSTMENT

Available in the following versions:
- with manual switch
- with time switch
- automatic with start every 12 doses and stop when the ground coffee doser is full

TECHNICAL FEATURES:

Power	650 Watt
Grinding Blades	Ø 83 mm (3¼ inches)
(single phase ref. 151A - three phase ref. 151B)	
Grinding blade speed	1400 (50 Hz) r.p.m.
	1600 (60 Hz) r.p.m.
Coffee-bean container capacity	1,8 Kg (4 lbs)
Net weight	20 Kg (44 lbs)



DOSIERMÜHLE MAJOR

STUFENLOSE MIKROMETRISCHE MAHLREGELUNG

Verfügbar in den folgenden Ausführungen:
- mit Handschalter
- mit Zeitschalter
- automatisch mit Start bei jeder 12 Dosis und Stop beim Auffüllen des Dosierers

TECHNISCHE DATEN:

Leistung	650 Watt
Mahlscheiben (einphasig Kennziffer 151A - dreiphasig Kennziffer 151B)	Ø 83 mm
Mahlscheibenumdrehungen	1400 (50 Hz) r.p.m.
	1600 (60 Hz) r.p.m.
Kapazität des Bohnenbehälters	1,8 Kg
Nettogewicht	20 Kg



MOLINO DOSIFICADOR MAJOR

REGULACIÓN MOLIENDA MICROMÉTRICA CONTINUA

Se suministran en las versiones:
- con interruptor manual
- con interruptor de tiempo
- automático con puesta en marcha cada 12 dosificaciones y parada cuando se llena el dosificador

DATOS TÉCNICOS:

Potencia	650 Watt
Fresas	Ø 83 mm
(monofásico ref. 151A - trifásico ref. 151B)	
Revoluciones fresas	1400 (50 Hz) r.p.m.
	1600 (60 Hz) r.p.m.
Capacidad de la tolva	1,8 Kg
Peso neto	20 Kg



MOINHO DOSEADOR MAJOR

REGULAÇÃO DA MOAGEM MICROMÉTRICA CONTINUA

Disponível nas versões:
- com interruptor manual
- com interruptor de tempo
- automático com partida a cada 12 doses e paragem após o enchimento do doseador

DADOS TÉCNICO:

Potencia	650 Watt
Mós	Ø 83 mm
(monofásico ref. 151A - trifásico ref. 151A)	
Rotações dos nós	1400 (50 Hz) r.p.m.
	1600 (60 Hz) r.p.m.
Capacidade tremonha	1,8 Kg
Peso líquido	20 Kg

CERTIFICATIONS



• Il costruttore si riserva la facoltà di apportare quelle modifiche tecniche che si rendessero necessarie senza preavviso. • The manufacturer reserves the right to change specifications without notice. • Le constructeur se réserve le droit d'effectuer des modifications sans aucun préavis. • Der Hersteller vorbehaltet sich den technischen Daten warnunglos zu ändern. • El constructor se reserva el derecho de efectuar sin previo aviso las modificaciones que considere oportunas en interés de mejoras técnicas en sus fabricados. • O constructor reserva-se o direito de modificar sem aviso previo as máquinas tratadas neste manual.

www.mazzer.com

MAZZER LUIGI s.r.l. Via Moglianese, 113 - 30037 Gardigliano di Scorzè (VE) - Italy

Tel. +39 041 5830200 - +39 041 5831300 - Fax +39 041 5830060 - E-mail: mazzer@mazzer.com - C.F. e P. IVA 00165200270



ISO 9001:2008
n. 9130.MAZZ